



US Department  
of Transportation  
Federal Aviation  
Administration

## MAJOR REPAIR AND ALTERATION (Airframe, Powerplant, Propeller, or Appliance)

Form Approved  
OMB No. 2120-0020  
11/30/2007

Electronic Tracking Number

For FAA Use Only

INSTRUCTIONS: Print or type all entries. See Title 14 CFR §43.9, Part 43 Appendix B, and AC 43.9-1 (or subsequent revision thereof) for instructions and disposition of this form. This report is required by law (49 U.S.C. §44701). Failure to report can result in a civil penalty for each such violation. (49 U.S.C. §46301(a))

<b>1. Aircraft</b>	Nationality and Registration Mark N4593H	Serial No. 15-357	
	Make Piper	Model PA-15	Series Vagabond
<b>2. Owner</b>	Name (As shown on registration certificate) David Grimm	Address (As shown on registration certificate) Address <u>4710 Penridge Rd.</u>	
		City <u>Toledo</u> State <u>OH</u>	Zip <u>43615</u> Country <u>USA</u>

### 3. For FAA Use Only

\*The alteration or repair identified herein complies with the applicable airworthiness requirements and is approved for use only on the above described aircraft, subject to conformity inspection by a person authorized in 43.7.\*

11/3/2010 Carol R. Wells 66-23  
Date Signature of FAA Inspector

4. Type		5. Unit Identification			
Repair	Alteration	Unit	Make	Model	Serial No.
<input type="checkbox"/>	<input checked="" type="checkbox"/>	AIRFRAME	_____	(As described in Item 1 above)	_____
<input type="checkbox"/>	<input type="checkbox"/>	POWERPLANT			
<input type="checkbox"/>	<input type="checkbox"/>	PROPELLER			
<input type="checkbox"/>	<input type="checkbox"/>	APPLIANCE	Type		
			Manufacturer		

### 6. Conformity Statement

<b>A. Agency's Name and Address</b>		<b>B. Kind of Agency</b>	
Name <u>David Grimm</u>		<input checked="" type="checkbox"/> U.S. Certificated Mechanic	Manufacturer
Address <u>4710 Penridge Rd.</u>		<input type="checkbox"/> Foreign Certificated Mechanic	C. Certificate No.
City <u>Toledo</u> State <u>OH</u>		<input type="checkbox"/> Certificated Repair Station	<u>A&amp;P 383605011</u>
Zip <u>43615</u> Country <u>USA</u>		<input type="checkbox"/> Certificated Maintenance Organization	

D. I certify that the repair and/or alteration made to the unit(s) identified in item 5 above and described on the reverse or attachments hereto have been made in accordance with the requirements of Part 43 of the U.S. Federal Aviation Regulations and that the information furnished herein is true and correct to the best of my knowledge.

Extended range fuel per 14 CFR Part 43 App. B <input type="checkbox"/>	Signature/Date of Authorized Individual <u>David Grimm</u> <u>11-6-2010</u>
--	--

### 7. Approval for Return To Service

Pursuant to the authority given persons specified below, the unit identified in item 5 was inspected in the manner prescribed by the Administrator of the Federal Aviation Administration and is  Approved  Rejected

BY	FAA Flt. Standards Inspector	Manufacturer	Maintenance Organization	Persons Approved by Canadian Department of Transport
	FAA Designee	Repair Station	Inspection Authorization	Other (Specify)

Certificate or Designation No.	Signature/Date of Authorized Individual <u>David Grimm</u> <u>11-6-2010</u>
--------------------------------	--

### NOTICE

Weight and balance or operating limitation changes shall be entered in the appropriate aircraft record. An alteration must be compatible with all previous alterations to assure continued conformity with the applicable airworthiness requirements.

#### 8. Description of Work Accomplished

(If more space is required, attach additional sheets. Identify with aircraft nationality and registration mark and date work completed.)

N4593H

Nationality and Registration Mark

Date

Removed fuel system from 337 dated 8-09-82 that had individual on-off valves for each fuel tank.

Installed a non header tank fuel system with one valve that has Off, Left, Right, and Both Tanks positions. This is similar to Cub Crafters STC SA00415SE non header tank fuel system for Piper PA-12 and PA-18 aircraft.

See attached diagram DWG#1 for fuel line routing and parts.

A ¼ inch fuel vent line was installed between fuel tanks using 3003 aluminum tube. Vent line attaches to upper fuel tank sight gauge fittings using Piper 488-371 T-fittings, MIL-H-6000-4 fuel hose and QS200-M10H clamps.

Per CAR 3 paragraph 3.448 both forward and aft fuel outlets on each wing tank (4 total) were fitted with finger strainers. AN840-6 nipple fittings are installed in fuel tank outlets. MIL-H-6000-6 fuel hose with QS200-M10H clamps connect to 3/8 fuel lines and AN fittings. Fuel lines were fabricated from 3003 Aluminum 3/8 tubing. AN union and 90 degree fittings are used as required. Line routing is similar to a Piper PA-18. Adel clamps secure fuel lines per AC43.13 1b Ch. 8 section 2 part 8-31 e-f.

Installed Dakota Cub Fuel Selector Valve DC11383 lower left sidewall of cockpit under instrument panel. STC SA02299AK allows for installation of this valve in Piper Model PA-11, 12, 14, 18, 19, 20, and J-3 aircraft. Dakota Cub fuel valve installation instructions followed with valve mounting accomplished by attachment to fuel valve panel. Valve panel attached to airframe by 10-32 machine screws and Adell clamps. AN fittings used as shown in Dakota Cub installation instructions see attached DCA11383-ICA sheet 2 of 3.

Fuel selector placard attached to panel with 12 gallon capacity noted for left and right tanks.

Placard installed on instrument panel indicating "TAKEOFF AND LANDING ON BOTH ONLY." Lettering is of contrasting color and letters are at least 3/8" in height.

Fuel Flow check verifies that this installation meets the required fuel flow rate in CAR Part 3, Paragraph 3.434, for an 85 HP Continental engine.

Fuel gauges are vinyl clear tube with fuel levels placarded for flight and ground attitudes.

Additional Sheets Are Attached

Additional Attached Sheet

N4593H

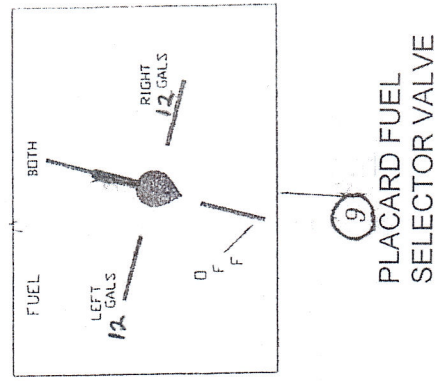
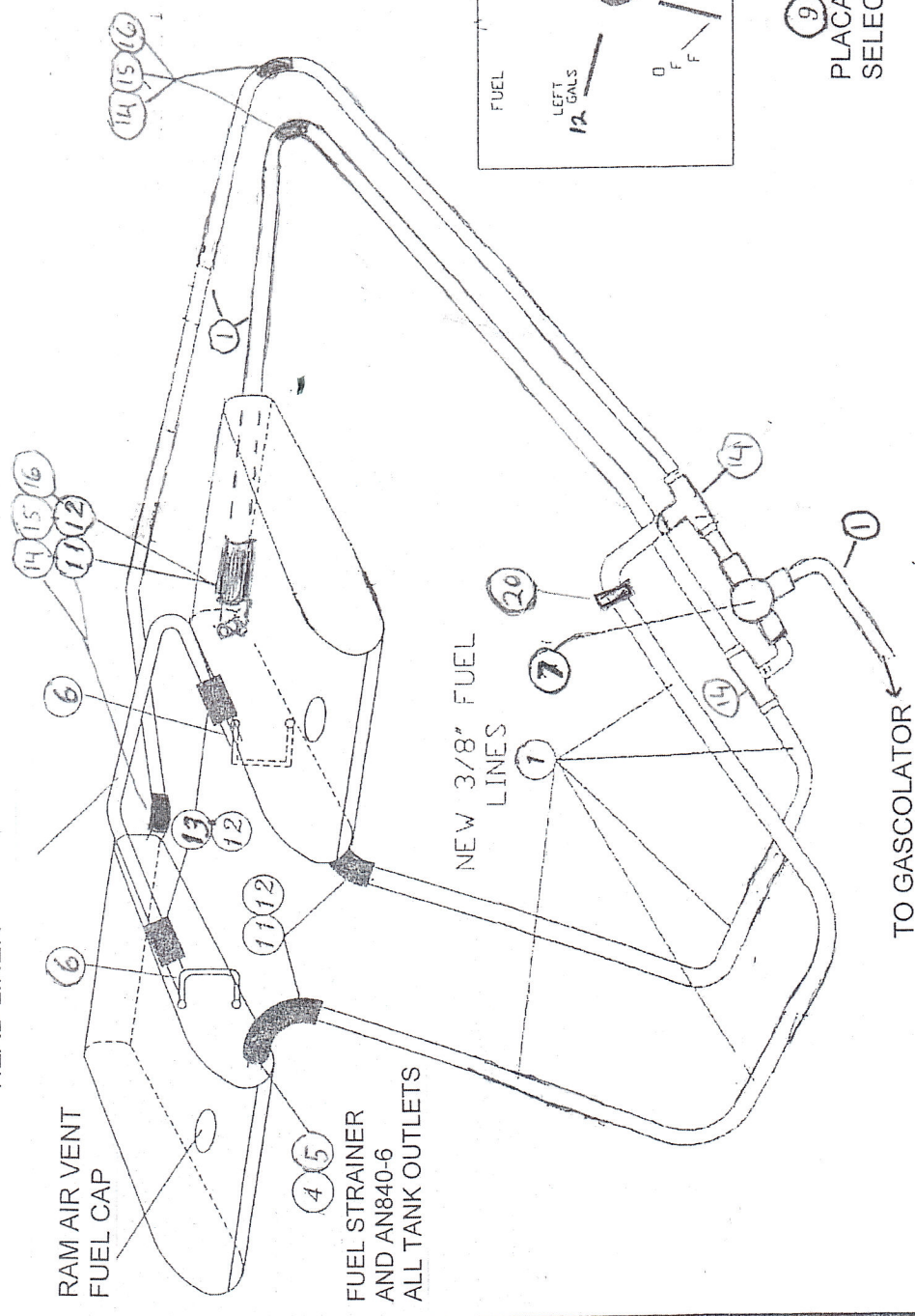
Nationality and Registration Mark

Date

**INSTRUCTIONS FOR CONTINUED AIRWORTHINESS: Fuel system for wing tanks on a PA15**

1. **INTRODUCTION:** Installation of a single selector valve non header tank fuel system in a PA-15 Aircraft equipped with dual wing tanks.
2. **DESCRIPTION:** Fuel lines pickup fuel from front and rear outlets on each wing tank. All fuel lines rout to a single four position fuel valve which feeds the aircraft gascolater. Fuel continues on to the carburetor as original.
3. **CONTROL, OPERATIONAL INFORMATION:** Fuel cap vents must face forward. Per installed instrument panel placard, Fuel selector valve must be on "BOTH" for take-off and landing.
4. **SERVICING INFORMATION:** No special information. Use standard aviation practices.
5. **MAINTENANCE INSTRUCTIONS:** For DC11383 selector valve use Dakota Cub DC11383 ICA sheet 1 and 2. Lines, hoses, and fittings refer to AC43.13 1b Ch. 8 Section 2 part 8-30 to 8-36.
6. **TROUBLE SHOOTING:** For DC11383 selector valve use Dakota Cub DC11383 ICA sheet 1 and 2. Lines, hoses, and fittings refer to AC43.13 1b Ch. 8 Section 2 part 8-30 to 8-36.
7. **REMOVAL / REPLACEMENT:** For DC11383 selector valve use Dakota Cub DC11383 ICA sheet 1 and 2. Lines, hoses, and fittings refer to AC43.13 1b Ch. 8 Section 2 part 8-30 to 8-36.
8. **DIAGRAMS:** Not Applicable
9. **SPECIAL INSPECTIONS:** Not Applicable
10. **APPLICATION OF PROTECTIVE TREATMENTS:** None Required.
11. **DATA:** Not Applicable
12. **LIST OF SPECIAL TOOLS:** None
13. **FOR COMMUTER CATEGORY AIRCRAFT:** Not Applicable
14. **RECOMMENDED OVERHAUL PERIODS:** No additional overhaul time limitations, On Condition.
15. **AIRWORTHINESS LIMITATIONS:** None
16. **REVISIONS:** A letter will be submitted to the local FSDO with a copy of the revised FAA Form 337 and revised ICA. The FAA inspector accepts the change by signing Block 3 and including the following statement: "The attached revised/new Instructions for Continued Airworthiness (date\_\_\_\_\_) for the above aircraft or component major alteration have been accepted by the FAA, superseding the Instructions for Continued Airworthiness (date\_\_\_\_\_)." Once the revision has been accepted, a maintenance record entry will be made, identifying the revision, its location, date of the Form 337.

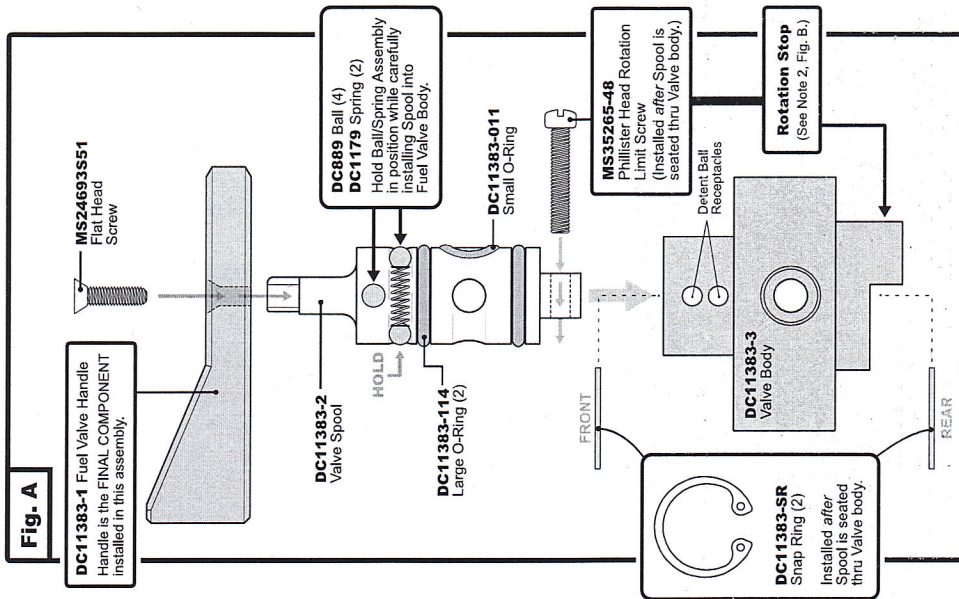
② NEW VENT LINE ROUTED ABOVE HEAD LINER



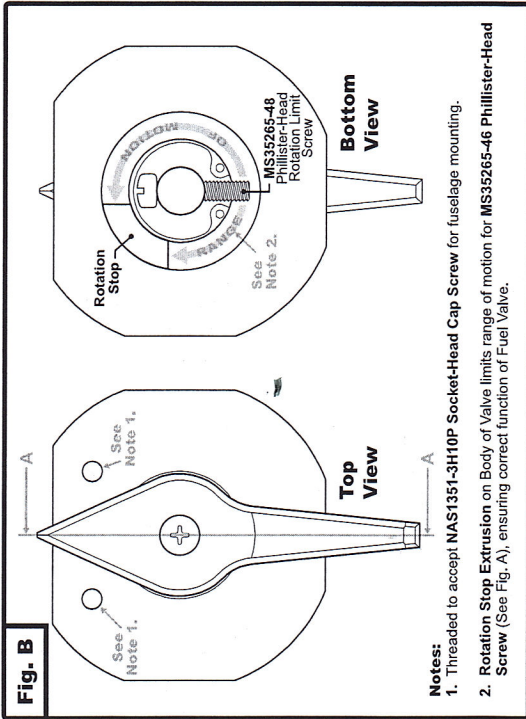
TAKE OFF AND LANDING ON BOTH ONLY

ITM	QTY	PART#	DECS.	ITM	QTY	DECS.
1	AR	N/A	3/8 OD X .032 WALL AL TUBE GRADE 3003	11	AR	MIL-H-6000-6 HOSE 3/8" ID
2	AR	N/A	1/4 OD X .032 WALL AL TUBE GRADE 3003	12	AR	QS100-M10H CLAMP
4	4	05-17700	FUEL STRAINER	13	AR	MIL-H-6000-4 HOSE 1/4" ID
5	4	AN840-6	NIPPLE 1/4 NPT X 3/8 OD	14	AR	AN821-6D 90 Elbow
6	2	488-371	TEE PIPER	15	AR	AN818-6D Coupling Nut
7	1	DC11383	FUEL VALVE DAKOTA CUB	16	AR	AN819-6D Sleeve
9	1	N/A	PLACARD FUEL VALVE	17	AR	AN815-6D UNION
10				20	AR	

# DC11383 Fuel Selector Valve Assembly

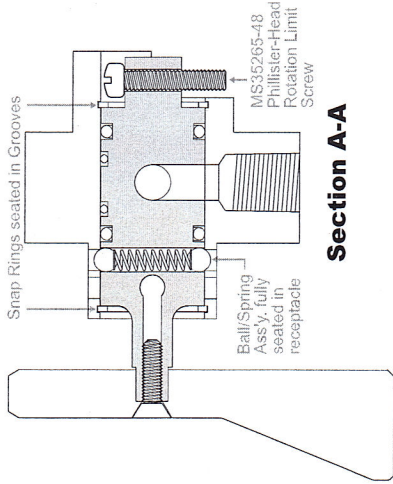


**Fig. A**

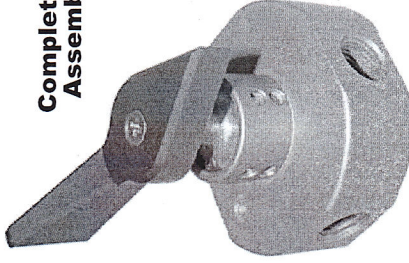


- Notes:**
1. Threaded to accept NAS1351-3H10P Socket-Head Cap Screw for fuselage mounting.
  2. Rotation Stop Extrusion on Body of Valve limits range of motion for MS35265-46 Phillister-Head Screw (See Fig. A), ensuring correct function of Fuel Valve.

## Section A-A



## Completed Assembly

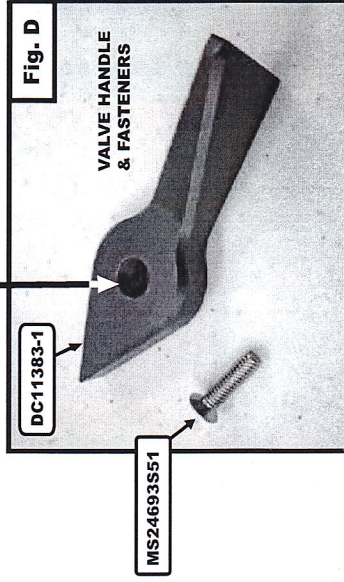
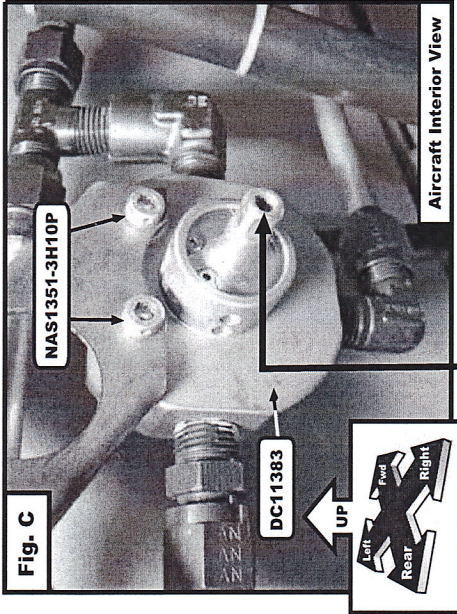
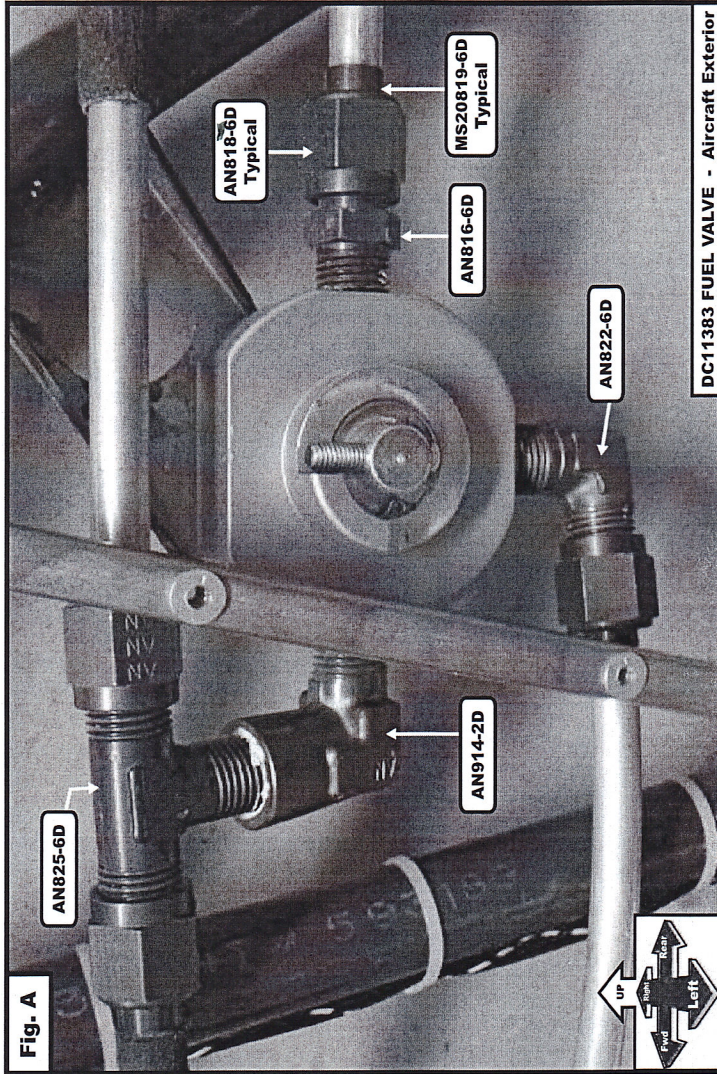


- Ensure that all components noted in figure A are clean of any contamination prior to assembly of DC11383 Fuel Selector Valve. Lubricate the bore of DC11383-3 Valve Body and DC11383-2 Valve Spool with Lubriplate #105 Motor Assembly Grease.
- Install DC11383-114 and DC11383-011 O-Rings onto DC11383 Spool at positions shown in figure A.
- The Spool has two spring bores at 90° to one another. Insert one DC1179 Spring and two DC889 Balls into each bore ( See fig. A).
- Holding Ball/Spring Assemblies in place, carefully insert Valve Spool into Valve Body as shown in Figure A. The Spool is correctly seated within Valve Body once both sets of Ball/Springs "snap" into their corresponding receptacles in upper section of Valve Body (See Section A-A).
- Install DC11383-SR Snap Rings into upper and lower snap ring grooves on Valve Body to secure Spool/Body Assembly. (See Figure A and Section A-A).
- With Spool seated and secured in Valve Body, install MS35265-48 Phillister-Head Rotation Locking Screw into bottom section of Spool, applying Loctite 242 Thread Locker to screw, and positioning as shown in figures A & B. Install DC11383-1 Handle onto Spool with MS24693S51 Flat Head Screw. Check for correct operation of completed assembly - rotate Handle, observing "Ball Detent Action" indicating positive location for each Valve position.

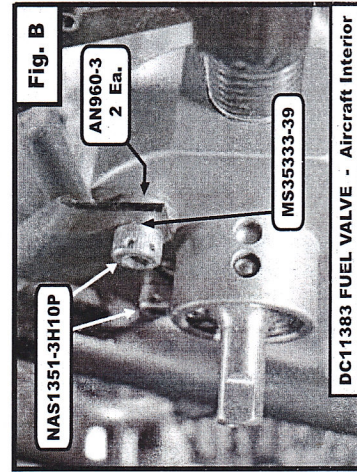
10	MS5265-48	1	8-32 x 7/8	Screw - Phillister Head Rotation Limit
9	MS24693S51	1 <td>8-32 x 5/8</td> <td>Screw - Flat Head</td>	8-32 x 5/8	Screw - Flat Head
8	DC1179	2		Spring - Fuel Valve
7	DC11383-SR	2		Snap Rings - Fuel Valve
6	DC11383-114	2		O-Ring (Large) - Fuel Valve
5	DC11383-011	2		O-Ring (Small) - Fuel Valve
4	DC889	4	3/16	Ball - Fuel Valve
3	DC11383-3	1		Body - Fuel Valve
2	DC11383-2	1		Spool - Fuel Valve
1	DC11383-1	1		Handle - Fuel Valve
				Description
				Material
				Part No.
				Size
				No. Req.
				Material
Scale: 1=1				
Unless Otherwise Specified				
MFG Practices - DCA Spec. No. 9 - Finish - DCA Spec. No. 10				
<b>FUEL VALVE ICA</b>				
DATE	5-03-07	CHECK	DATE	5-03-07
DATE	5-03-07	CHECK	DATE	5-03-07
<b>DAKOTA CUB AIRCRAFT</b>				
Box 197 Brendon, SD				
Drawing No. - DC11383-ICA				
Sheet 1 of 3				

MFG PRACTICES / DCA GENERAL MECHANICAL - 1			
ALL DATA PROPRIETARY TO DAKOTA CUB AIRCRAFT			
Unless Otherwise Specified	Angles ±.2°	DATE	BY
MFG Practices	Fractions ±.001	REVISION	LET
	.0 ±.002		
	.000 ±.010		

# DC11383 Fuel Selector Valve Installation

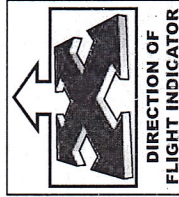


- Notes:
1. All NPT Joints sealed with non-hardening thread sealing compound suitable for use with aviation and automotive grade fuels.
  2. Primary locking for valve cap screws - MS35333-39 Washer. Alternate locking method - safety wire per AL43.13 between NAS 1351-3H10P Cap Screws.



QTY	Part No.	No. Req.	Material
1	MS24693S51	1	Screw - Flat Head
1	MS20995	1	Safety Wire
1	MS35333-39	2	Internal Star Washer
2	NAS1351-3H10P	2	Socket Head Cap Screw
4	AN818-6D	4	Tube Nut
4	MS20819-6D	4	Sleeve
1	AN914-2D	1	Elbow
1	AN816-6D	1	Nipple - Flare to Pipe
4	AN822-6D	4	Washer
1	DC11383-1	1	Valve Assembly
1	DC11383	1	Valve
1		1	Description
			Material

Scale: 1=1  
MFG Practices - DCA Spec. No. 9 - Finish - DCA Spec. No. 10



REVISION	DATE	BY

ALL DATA PROPRIETARY TO DAKOTA CUB AIRCRAFT  
MFG PRACTICES / DCA GENERAL MECHANICAL - 1

Unless Otherwise Specified Tolerances:  
 Angles ± 2°  
 Fractions ± 1/32  
 .0 ± .032  
 .00 ± .020  
 .000 ± .010

DAKOTA CUB AIRCRAFT Box 797  
Brandon, SD

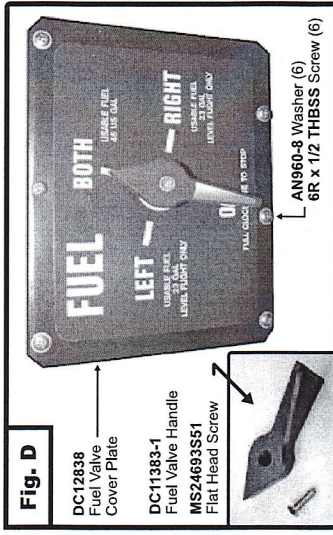
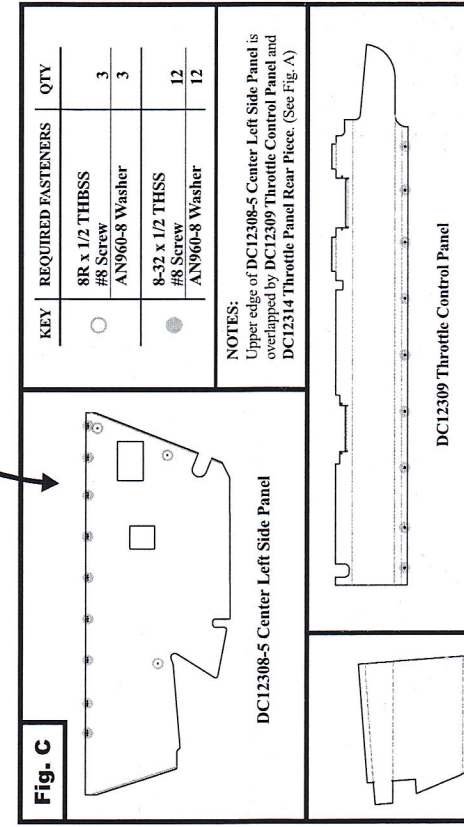
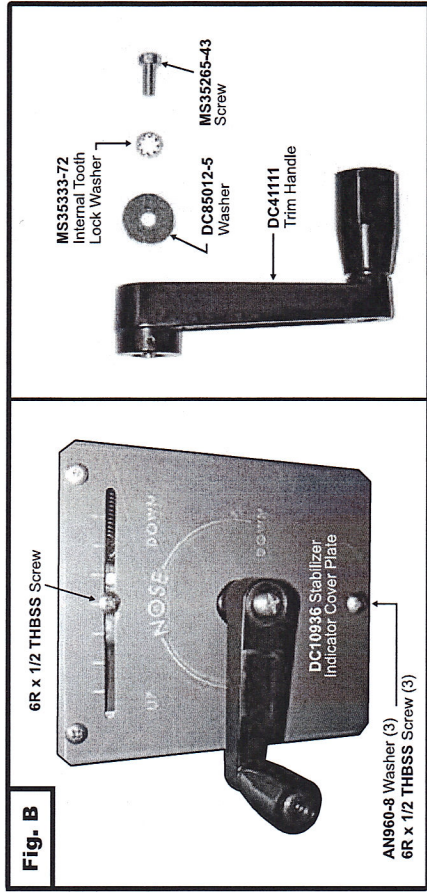
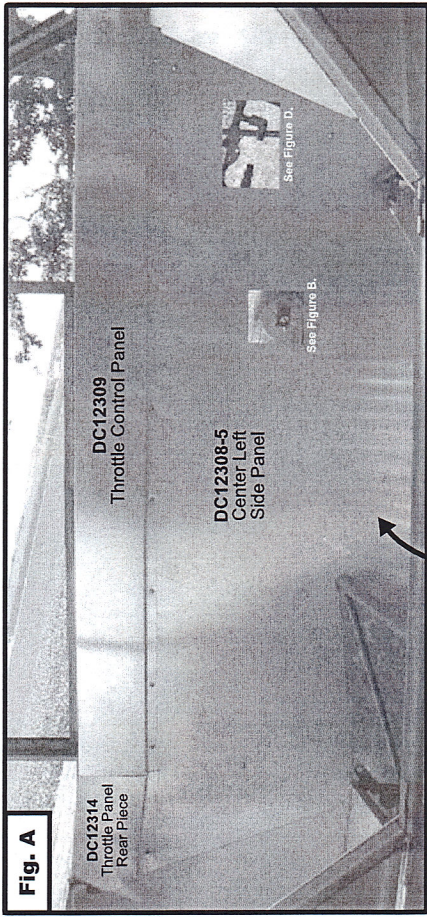
## FUEL VALVE ICA

DC11383-ICA

Check - MDE  
DATE - 5-03-07

DWG. MDE  
DATE - 5-30-07

Drawing No. - DC11383-ICA



- DC11383 Fuel Selector Valve Access from Aircraft Interior**
- A. Access to DC11383 Fuel Selector Valve is achieved by unfastening the Fuel Valve Handle and removing the Fuel Valve Cover Plate from the Center Left Side Panel. (Refer to Figs. A & D.)
- B. If further access is required, the Trim Handle and Stabilizer Indicator Cover Plate must be removed (See Fig. B) so that DC12314 Throttle Panel Rear Piece, DC12309 Throttle Control Panel, DC12308-5 Center Left Side Panel can be removed as well (See Figs. A & C).

KEY	REQUIRED FASTENERS	QTY
○	8R x 1/2 THBSS #8 Screw	3
○	AN960-8 Washer	3
●	8-32 x 1/2 THBSS #8 Screw	12
●	AN960-8 Washer	12

NOTES:  
Upper edge of DC12308-5 Center Left Side Panel is overlapped by DC12309 Throttle Control Panel and DC12314 Throttle Panel Rear Piece. (See Fig. A)

MFG PRACTICES / DCA GENERAL MECHANICAL - 1			
Part No.	No.	Size	Description
15	12		#8 Screw - True Head, Stainless Steel
14	3		8R x 1/2 THBSS
13	10		6R x 1/2 THBSS
12	24		Washer
11	1		Lock Washer - Internal Tooth
10	1		Screw - Phillips Head
9	1		Screw - Flat Head
8	1		MS35333-72
7	1		MS24693S51
6	1		DC10936
5	1		DC11383-1
4	1		DC12838
3	1		DC41111
2	1		DC65012-5
1	1		DC12309
1	1		DC12308-5
1	1		DC12314

MFG PRACTICES - DCA Spec. No. 9 - Finish - DCA Spec. No. 10			
DWG.	MDE	Check - MDE	Drawing No.
DATE	5-03-07	DATE	5-03-07
FUEL VALVE ICA			DC11383-ICA

Scale: 1:1

ALL DATA PROPRIETARY TO DAKOTA CUB AIRCRAFT

Unless Otherwise Tolerances -

Angles = ± 2°

Fractions = ± 1/32

.00 = ± .020

.000 = ± .010

LET. REVISION DATE BY

DAKOTA CUB AIRCRAFT Box 797 Brandon, SD