

SERVICE



LETTER

Service Letter No. 129

October 28, 1949

TO: All Owners of Model PA-17 Airplanes Serial 17-1 and up.
All Owners of Model PA-15 Airplanes Equipped with Model PA-17 Type
Landing Gear Shock Struts

SUBJECT: Inspection of Landing Gear Shock Strut End Fittings

It is recommended that the upper and lower shock strut end fitting attachment bolts be inspected for excessive tightness.

The end fittings (Part No. 11806 - four per airplane) should be sufficiently loose to allow the bolt to turn freely with a 5" end wrench.

Examine the end fittings for possible cracks in the small bend radius, caused by extreme tightening of the attachment bolts.

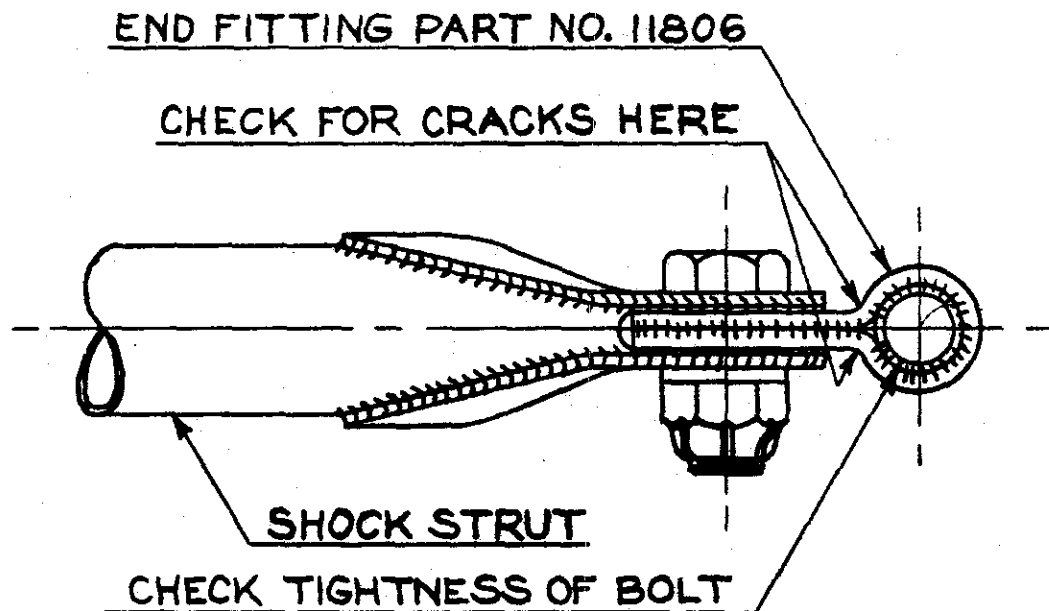

PIPER AIRCRAFT CORPORATION

R. Boardman
Rolland Boardman
Service Manager

RB:lh

PIPER AIRCRAFT CORPORATION, LOCK HAVEN, PA., U. S. A.