



# SERVICE LETTER

No. 329A

Piper Aircraft Corporation  
(Supersedes Service Letter No. 329)

Lock Haven, Pennsylvania, U.S.A.  
May 17, 1960

---

**TO:** All Distributors, Dealers, Owners and Piper Certified Service Centers

**SUBJECT:** Inspection of Oil Cooler Lines, Oil Cooler Line Securing Clamps and Oil Cooler Line Attachments to Oil Radiator

**MODEL AFFECTED:** PA-22 - Serial Nos. 22-3886 to 22-6879 inclusive

This Service Letter is issued to remind all those concerned with the inspection and maintenance of the subject airplanes, that when conducting routine inspections of the oil cooler lines and fittings, particular attention should be given to the following:

1. Oil Cooler line attachments (compression nuts) should be examined to be certain that all are tight and there is no indication of cross threading.
2. The compression nuts must be checked to make certain uniform clearance exists between the oil line and the compression nut.
3. Oil lines must have adequate clearance and be properly aligned--engine to cooler.
4. Oil line support brackets and retaining blocks should be tight, properly positioned and, if worn, must be replaced.

Improperly installed compression nuts, misalignment of oil cooler lines, worn or loose retaining blocks may result in a broken oil line and loss of power.

We wish to advise that on Serial Nos. 22-6880 and up the oil radiator lines were equipped with compression nuts containing a floating insert, part number 14623-00 - 14624-00. These new oil lines will reduce the effects of misalignment and vibration and recommend that on Serial Nos. 22-3886 to 22-6879 inclusive, these improved lines be installed if present lines do not incorporate compression nuts with floating inserts.

Serial Nos. 22-6760, 22-6761, 22-6763 and up were equipped with improved oil line retaining blocks, part number 15020-00, and brackets, part number 15019-00. These will aid in further reducing the effects of misalignment and vibration. We recommend the installation of the new type retaining block and bracket on Serial Nos. 22-3886 to 22-6759 inclusive and 22-6762. See Sketch on reverse side.

(Over)

The above parts may be ordered through your Piper distributor.

Very truly yours,

PIPER AIRCRAFT CORPORATION

*Wes Holmes*  
Wes Holmes  
Service Manager

WH:pz

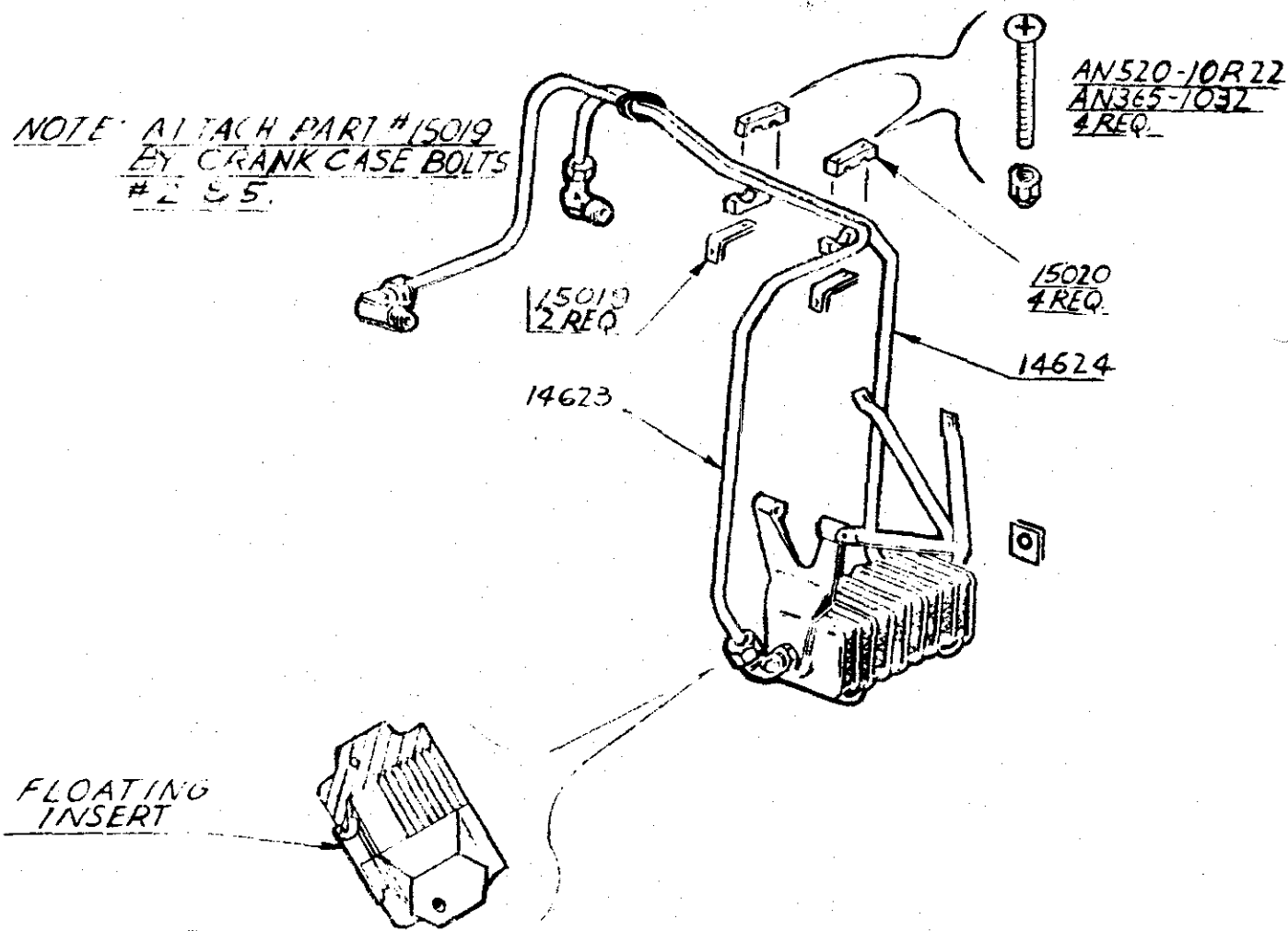

NOTE:  
OIL COMPRESSION NUT SEAL  
RING ALL OVER BEFORE  
TIGHTENING. TIGHTEN TO  
125 IN. LBS. THEN SAFETY.

SERVICE LETTER 329 A