



# SERVICE LETTER

No. 392

Piper Aircraft Corporation

Lock Haven, Pennsylvania, U.S.A.  
January 17, 1963

---

**TO:** Distributors, Dealers, Certified Service Centers and Owners

**SUBJECT:** Inspection and Adjustment of Nose Wheel Shimmy Dampener Assembly

**MODELS AFFECTED:** All PA-22 Series Aircraft

**DATE OF COMPLIANCE:** Aircraft Equipped with Shimmy Dampener, Part No. 13086-00 -- prior to but not later than next 25 hours of operation

Aircraft Equipped with Shimmy Dampener, Part Nos. 21701-02 or 21701-04 -- prior to but not later than next 100 hour inspection

It is possible, during maintenance, repair or installation, that the nose wheel steering and the rudder adjustment may become maladjusted. Care must be taken to assure that rudder and nose wheel travels are within Piper specified tolerances as indicated in the Owner's Handbook.

- I. Should the above systems become maladjusted on aircraft equipped with the early model nose wheel shimmy dampener, part number 13086-00, it is possible that, in a maximum left turn, the shaft of the shimmy dampener may enter the end of the dampener housing and jam; thus making any further movement of the nose wheel impossible.
- II. It may also be possible that, through lack of attention during maintenance and inspection, the shimmy dampener may "freeze" to its attachment to the nose wheel structure. In other words, at large angles of nose wheel steering, relative angular travel must be maintained for the dampener. Should the bolt which attaches the dampener become corroded to the supporting structure etc., it would be possible to bend the shaft at the point where it exits from the dampener body.
- III. Freedom of angular travel must also be maintained at the point where the rod end attaches to the nose wheel steering arm. Lack of angular travel at this point could cause bending of the dampener shaft or bending of the rod end with possible failure of the rod end in the threads.

(over)

---

January 17, 1963

In view of the above, the following inspection will be required. On the Monroe type shimmy dampeners, part numbers 21701-02 and 21701-04, prior to but not later than the next 100 hours of operation and becoming part of the normal maintenance and routine inspection thereafter. On aircraft equipped with the earlier type shimmy dampener, part number 13086-00, prior to but not later than the next 25 hours of operation and becoming a part of the normal maintenance and routine inspection thereafter: (Refer to attached sketch)

1. Determine that the nose wheel travel is 20° left and right.
2. Determine that the shimmy dampener rotates freely on the axis of its attachment bolt when approaching the limits of nose wheel travel.
3. Determine that the attachment of the rod end to the nose wheel steering arm is free to accept angular travel.
4. The shimmy dampener should be adjusted, if necessary, so that at full left nose wheel travel, not less than 1/4 inch of the shaft shall be exposed on the back side of the dampener. (Applicable to early type shimmy dampener, part number 13086-00 only.)

In many cases, older aircraft will be equipped with the new style shimmy dampeners, part numbers 21701-02 or 21701-04, as service replacements and practically all PA-22 series aircraft, from serial number 22-6066 and up will be equipped with the Monroe Dampener unless the earlier type shimmy dampener, part number 13086-00, has been used as a service replacement.

Very truly yours,

PIPER AIRCRAFT CORPORATION

  
Wes Holmes  
Service Manager

WH:dld

SERVICE LETTER 392

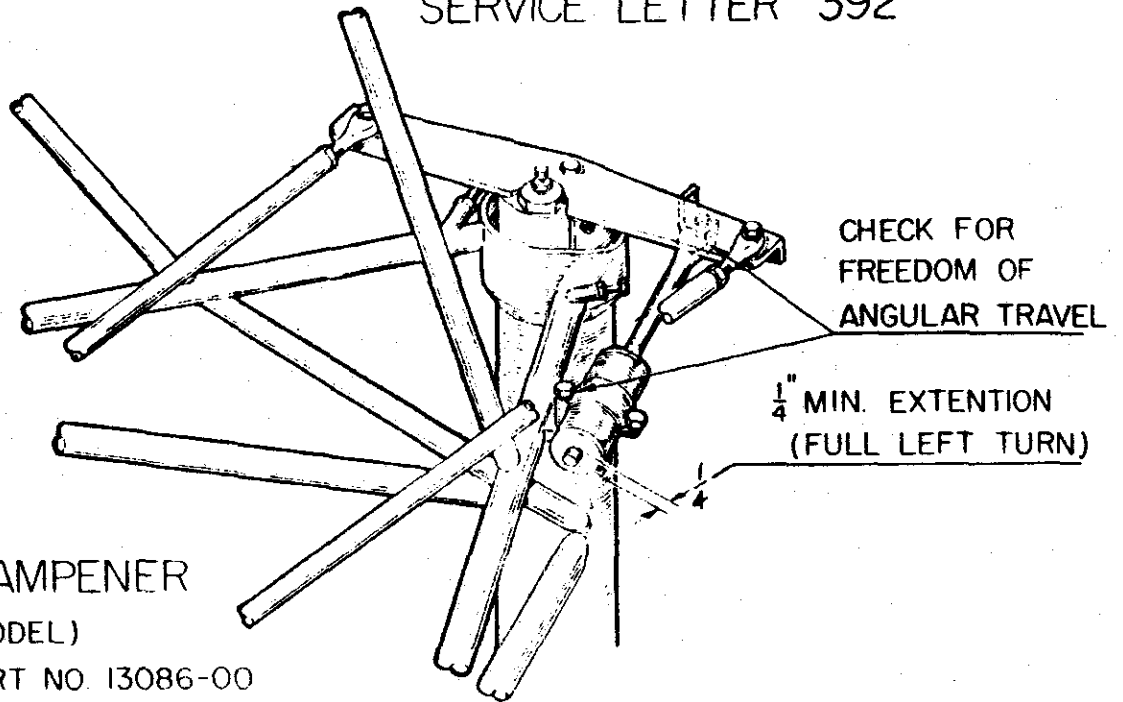

SHIMMY DAMPENER

(EARLY MODEL)

TRI-PACER-PART NO. 13086-00

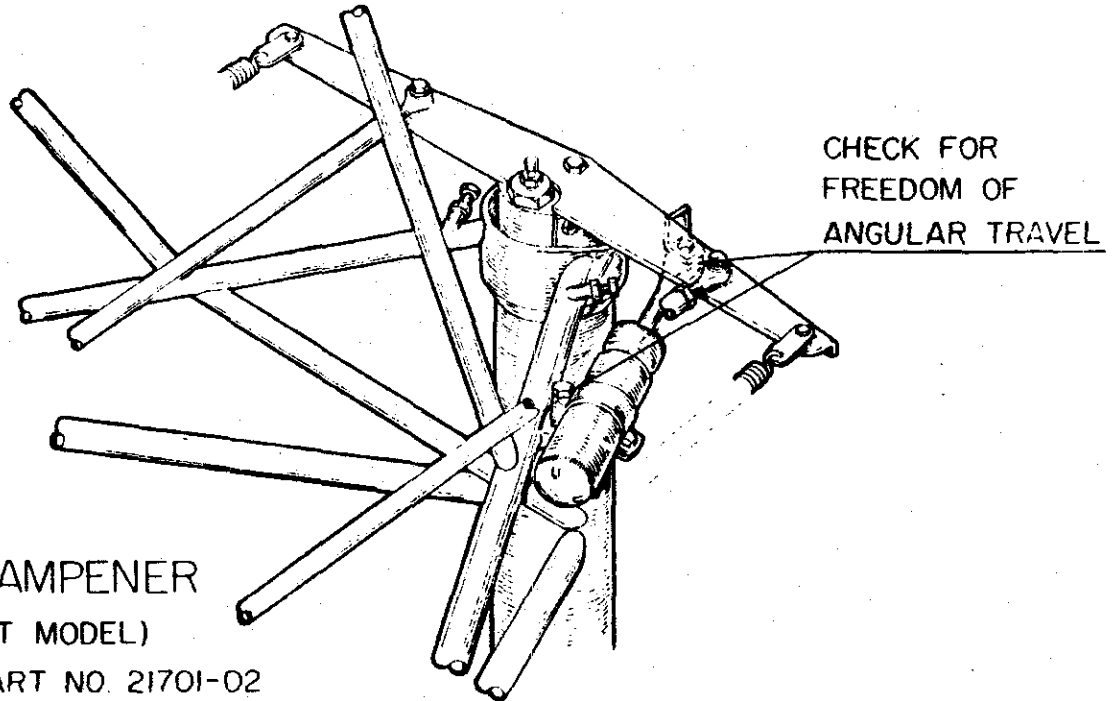

SHIMMY DAMPENER

(PRESENT MODEL)

TRI-PACER-PART NO. 21701-02

COLT-PART NO 21701-04