



Customer Services

SERVICE LETTER

No. 410

Piper Aircraft Corporation

Lock Haven, Pennsylvania, U.S.A.
October 16, 1963

TO: Distributors, Dealers, Certified Service Centers and Owners
SUBJECT: Inspection and Lubrication of Stabilizer Yoke and Yoke Screw
MODELS AFFECTED: All PA-22 Series Aircraft

This Service Letter is to advise owners and operators of the subject aircraft that at each 100 hour inspection, the bushing, washer and nut of the stabilizer yoke assembly should be inspected for wear and, if worn, should be replaced.

At this time, the bushing and surfaces of the washer should be lubricated.

See sketch on the reverse side of this Service Letter for details of inspection and lubrication requirements.

Very truly yours,

PIPER AIRCRAFT CORPORATION

Wes Holmes
Service Manager

WH:dld

(over)

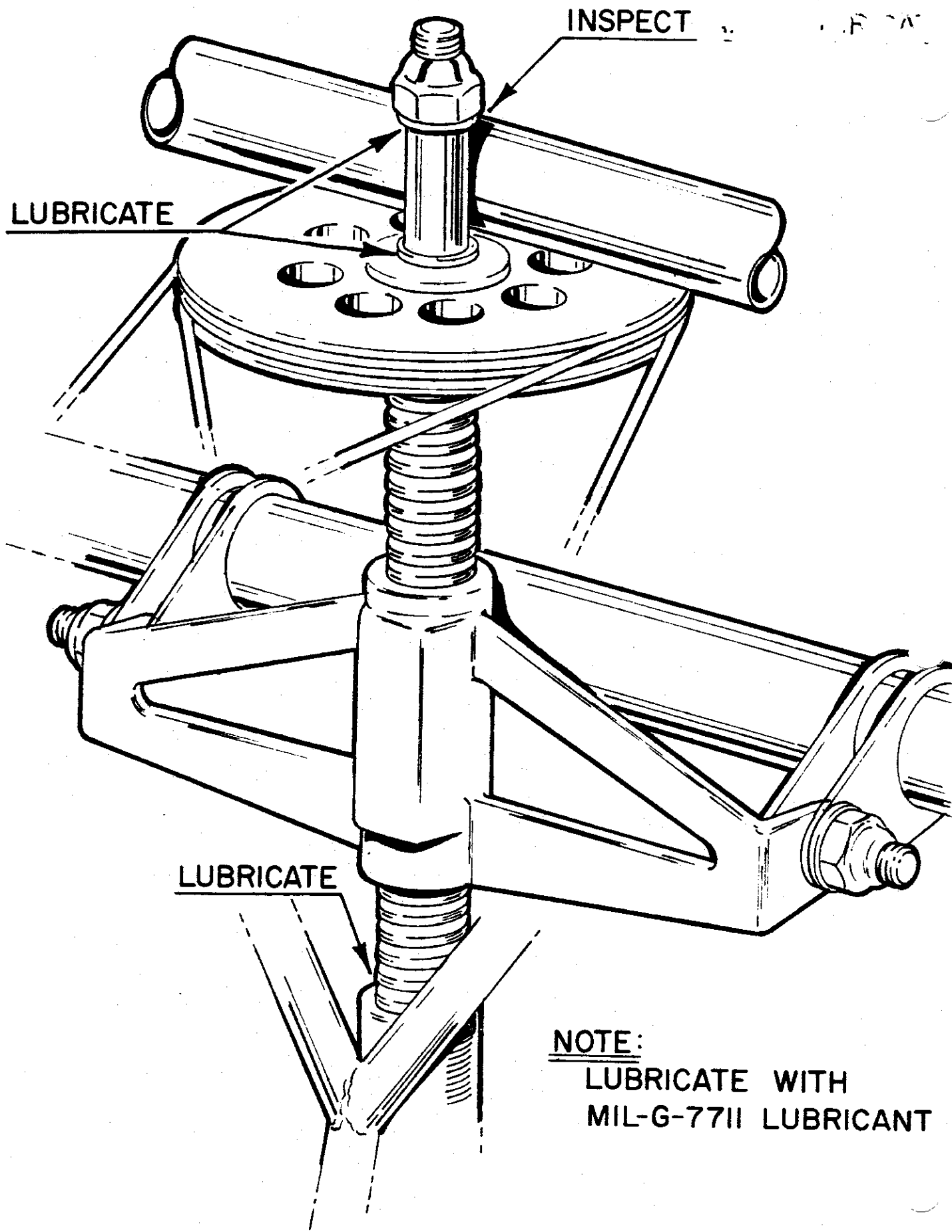

INSPECT

LUBRICATE

LUBRICATE

NOTE:
LUBRICATE WITH
MIL-G-77II LUBRICANT

SERVICE LETTER 410